

THIS DOCUMENT MUST NOT BE COPIED WITHOUT OUR WRITTEN PERMISSION, AND THE CONTENTS THEREOF MUST NOT BE IMPARTED TO A THIRD PARTY NOR BE USED FOR ANY UNAUTHORIZED PURPOSE. CONTRAVENTION WILL BE PROSECUTED.

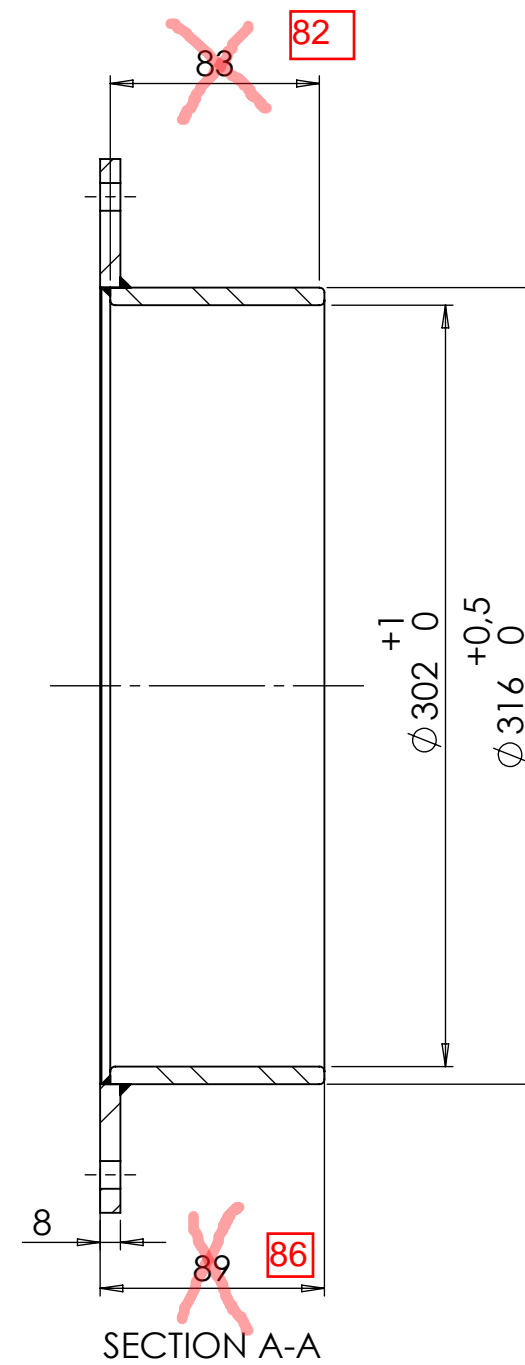
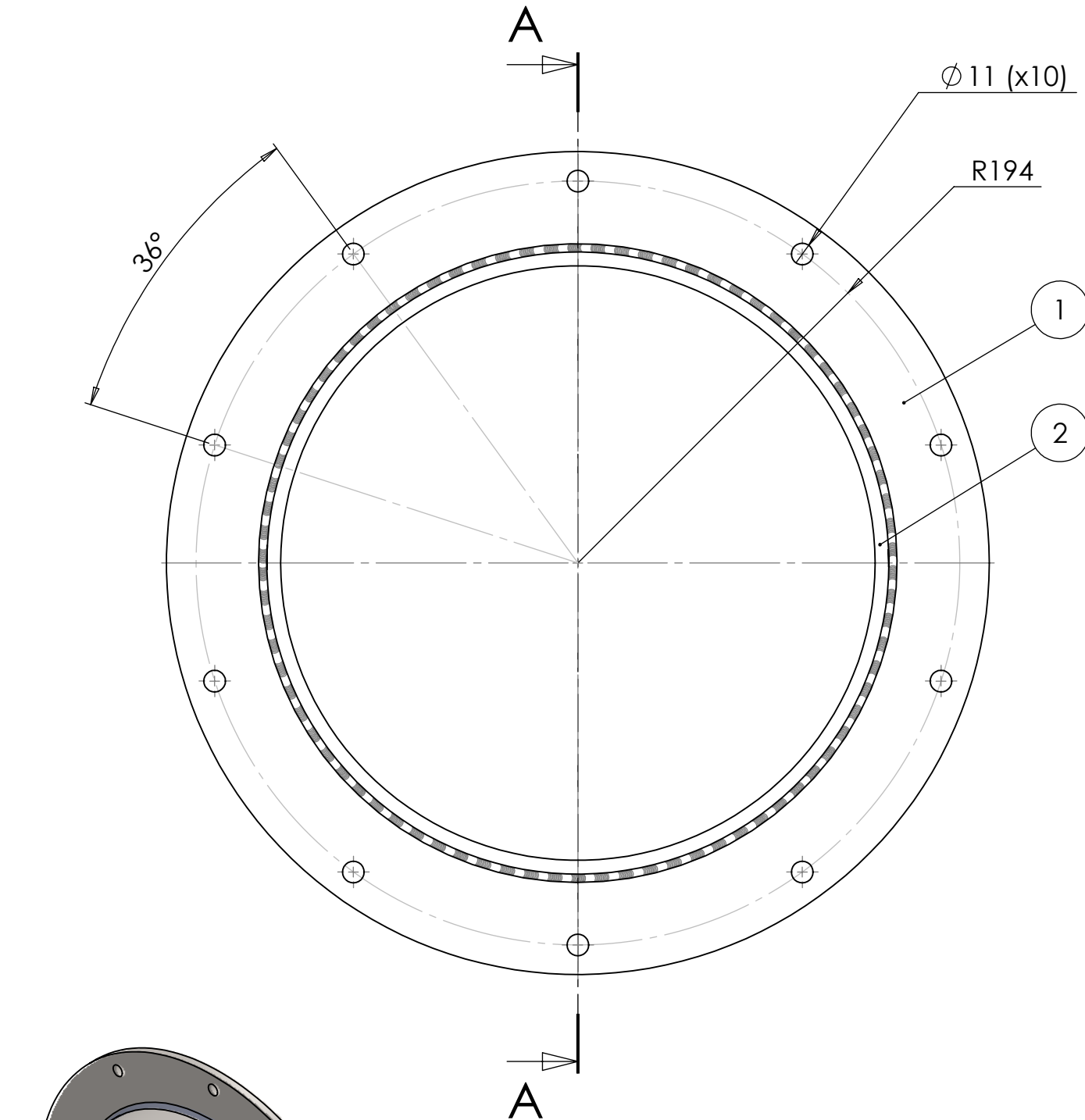

REVISIONS			
REV.	DESCRIPTION	DATE	SIGNATURE
A		2020-04-08	JA

ITEM NO.	TITLE	DRAW. No. / DESCRIPTION / MATERIAL		QTY.
1	FLANGE	1200156		1
2	PIPE SLEEVE-300	130446		1
Ritad Drawn	Kontr. Check	Granskad Reviewed	Godkänd Approved	Tolerans där ej annat anges Tolerance unless otherwise not stated. ISO 13920-BF
JA	JA	LS	ML	Smst. nr. Assembly drawing no.
200407	200408	200414	200414	Ersätter Replaces 110088
				E
Ytjämnhet där ej annat anges. Surface finish otherwise not stated.				Vikt Weight 8,2 KG
Alla mått och uppgifter avser färdig produkt om ej annat anges. All measures and other information refer to finished products unless otherwise not stated.				
SFRB-300				Kund ordernr. Customer order no
Ritn. nr. Draw. no.				Rev.
1200155				A