

THIS DOCUMENT MUST NOT BE COPIED WITHOUT OUR WRITTEN PERMISSION, AND THE CONTENTS THEREOF MUST NOT BE IMPARTED TO A THIRD PARTY NOR BE USED FOR ANY UNAUTHORIZED PURPOSE. CONTRAVENTION WILL BE PROSECUTED.

REVISIONS

REV.	DESCRIPTION	DATE	SIGNATURE
A		2018-10-22	JA
B	ADDED FRONT / BACK PLATE AND SEAL DRAW. NO IN BOM	2020-08-07	JA
C	UPDATED BOM	2024-04-11	SS

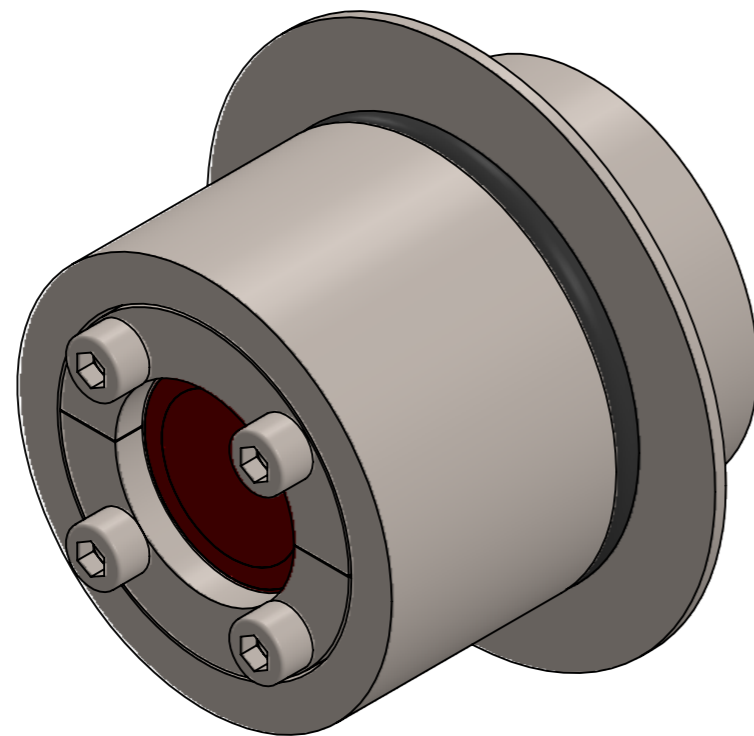
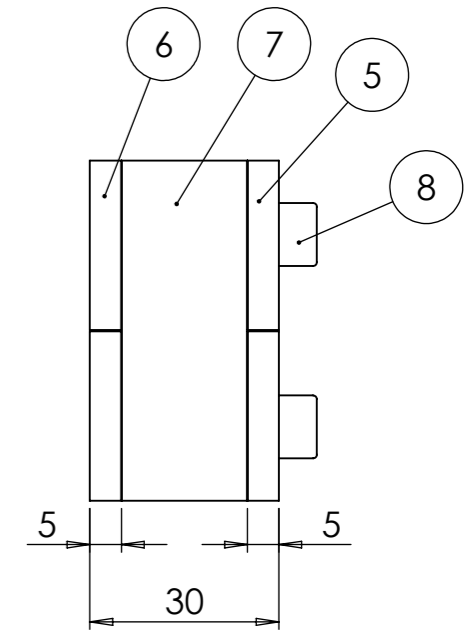
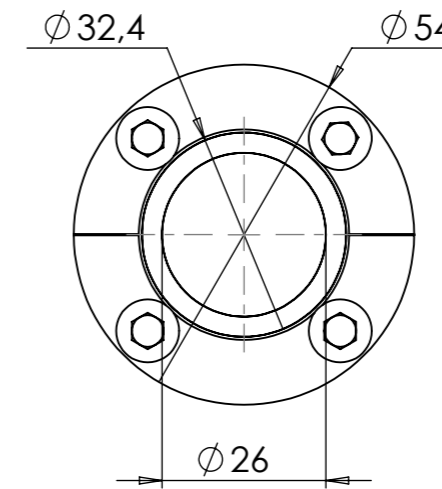
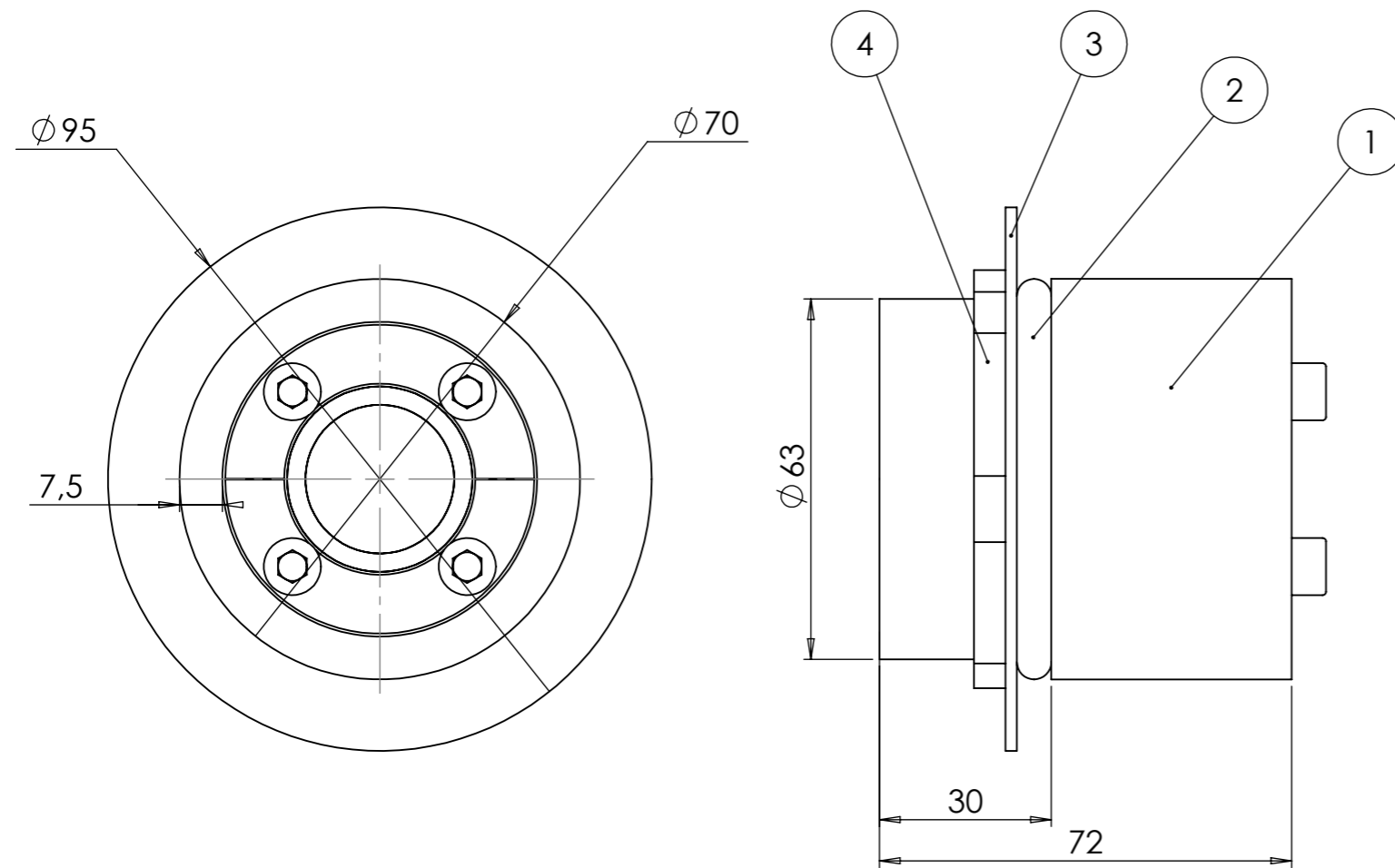

ITEM NO.	TITLE	DRAW. No. / DESCRIPTION / MATERIAL	QTY.
1	MSR 63 HOUSE	1 100839	1
2	ORING	EPDM	1
3	WASHER	1 100840	1
4	NUT	NICKEL PLATED BRASS	1
5	FRONT PLATE	1200324	1
6	BACK PLATE	1200324	1
7	SEAL	1200325	1
8	SCREW	M6 x 30	4

Ritad Drawn	Kontr. Check	Granskad Reviewed	Godkänd Approved	Tolerans där ej annat anges Tolerance unless otherwise not stated. ISO 2768 M	Smt. nr. Assembly drawing no.	Ersätter Replaces	E
JA	SS	OF	ML	Ytjämnhet där ej annat anges. Surface finish otherwise not stated.	Material	Ersatt av Replaced of	Vikt Weight
181022	240411	240411	240412			Alla mått och uppgifter avser färdig produkt om ej annat anges. All measures and other information refer to finished products unless otherwise not stated.	

MCT BRATTBERG

MSR-63 TYPE 3

Kund ordernr.
Customer order no

Ritn. nr.
Draw. no. 1180416

Rev. C