

THIS DOCUMENT MUST NOT BE COPIED WITHOUT OUR WRITTEN PERMISSION, AND THE CONTENTS THEREOF MUST NOT BE IMPARTED TO A THIRD PARTY NOR BE USED FOR ANY UNAUTHORIZED PURPOSE. CONTRAVENTION WILL BE PROSECUTED.

REVISIONS			
REV.	DESCRIPTION	DATE	SIGNATURE
B	UPDATED BOM	2024-04-11	SS

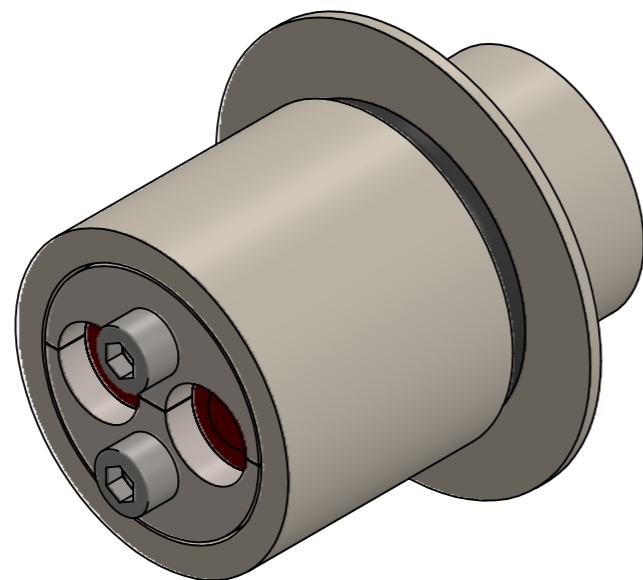
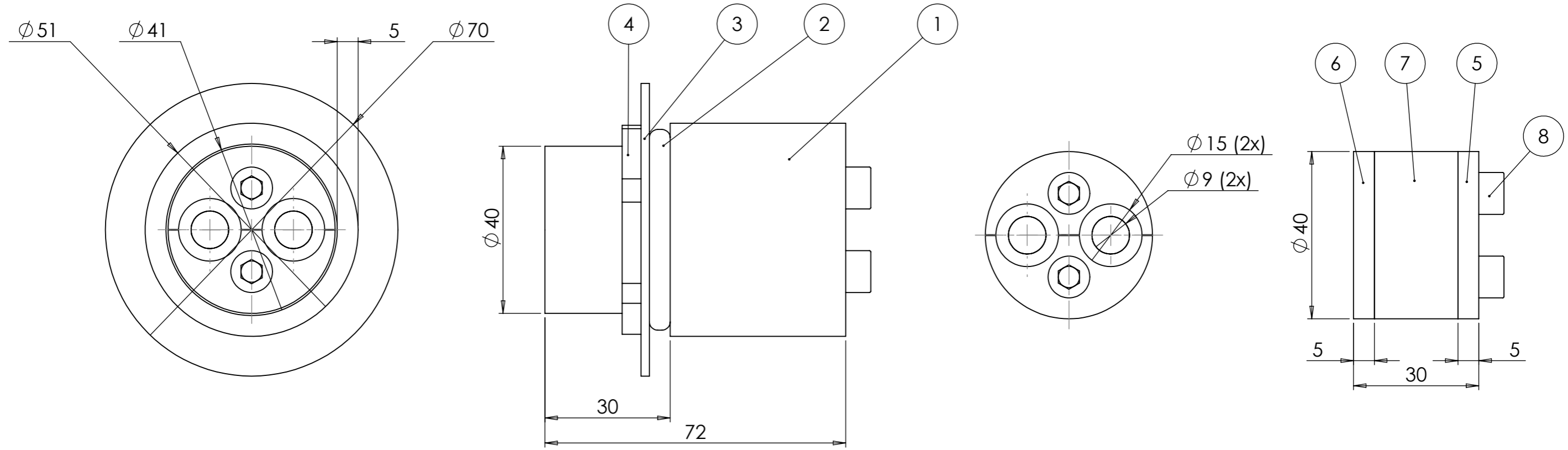

ITEM NO.	TITLE	DRAW. No. / DESCRIPTION / MATERIAL	QTY.
1	MSR 40 HOUSE	1 100837	1
2	ORING	EPDM	1
3	WASHER	1 100840	1
4	NUT	NICKEL PLATED BRASS	1
5	FRONT PLATE TYPE 2		1
6	BACK PLATE TYPE 2		1
7	RUBBER SEAL TYPE 2		1
8	SCREW	ISO 4762 - M6 x 30	2

Ritad Drawn	Kontr. Check	Granskad Reviewed	Godkänd Approved	Tolerans där ej annat anges Tolerance unless otherwise not stated.	Smsl. nr. Assembly drawing no.	Ersätter Replaces	E
JA	SS	OF	ML	Ytjämnhet där ej annat anges. Surface finish otherwise not stated.	Material	Ersatt av Replaced of	Vikt Weight 0,5 Kg
170908	240411	240411	240412			Alla mått och uppgifter avser färdig produkt om ej annat anges. All measures and other information refer to finished products unless otherwise not stated.	
				MSR-40 TYPE 2		Kund ordernr. Customer order no	
						Ritn. nr. Draw. no.	Rev.
1170222		B					