

THIS DOCUMENT MUST NOT BE COPIED WITHOUT OUR WRITTEN PERMISSION, AND THE CONTENTS THEREOF MUST NOT BE IMPARTED TO A THIRD PARTY NOR BE USED FOR ANY UNAUTHORIZED PURPOSE. CONTRAVENTION WILL BE PROSECUTED.

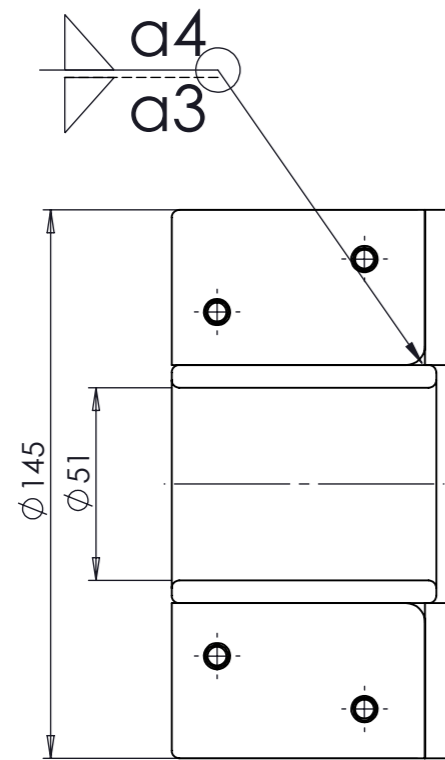

SECTION A-A

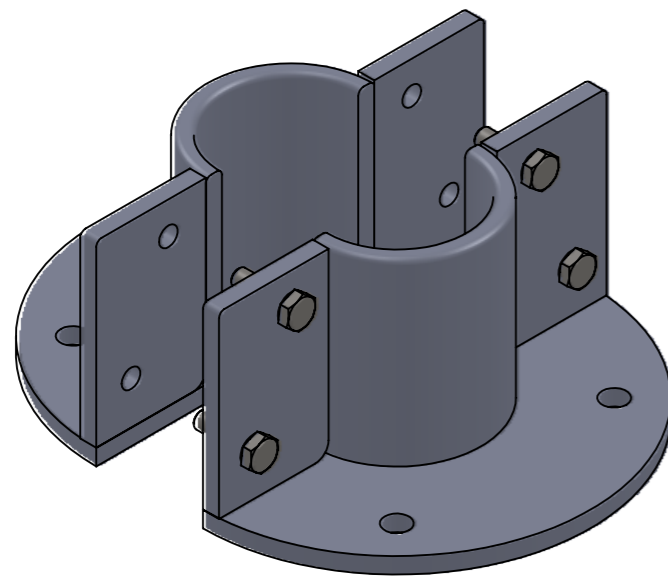
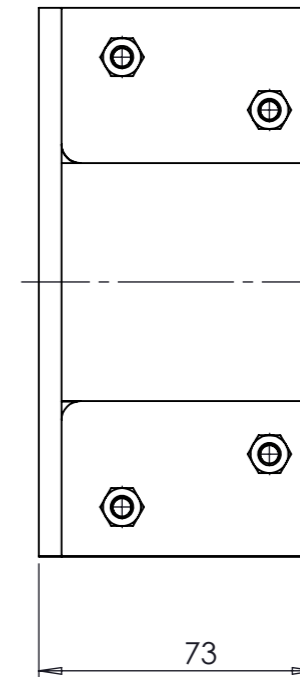
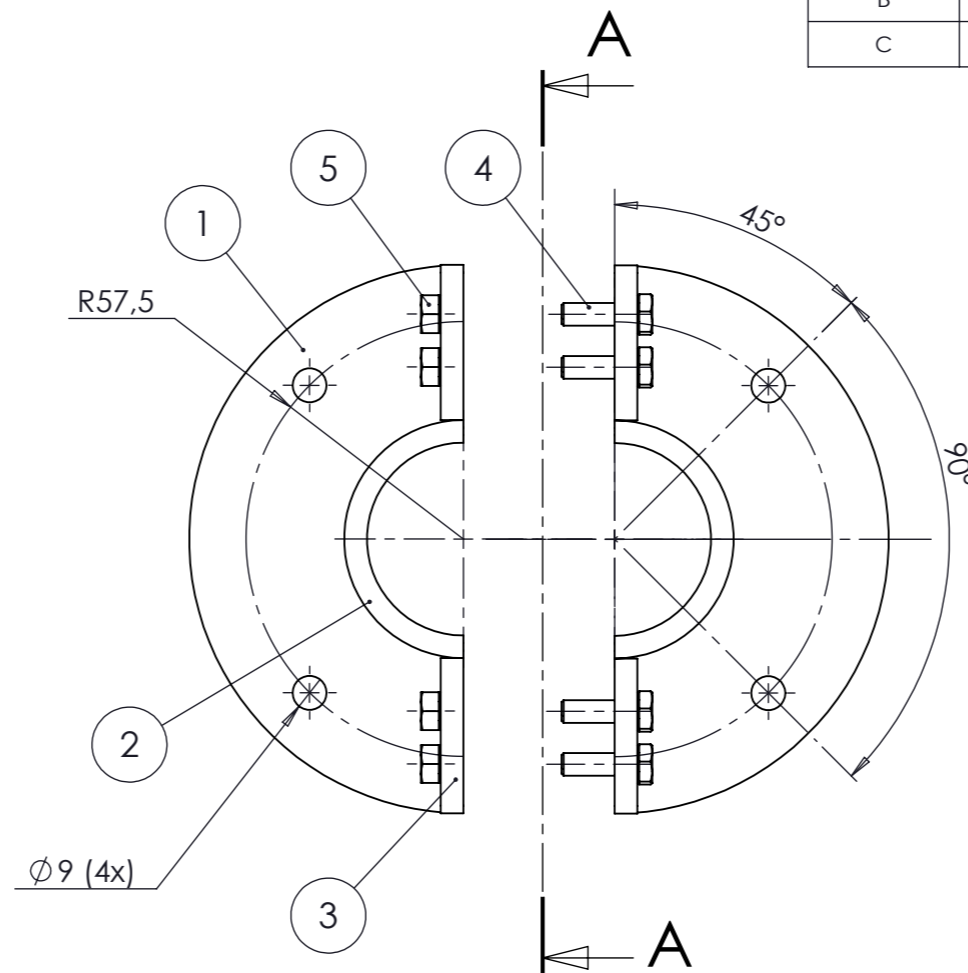

REVISIONS			
REV.	DESCRIPTION	DATE	SIGNATURE
A	FOR MANUFACTURING	2011-08-26	BO
B	CHANGED HOLE PATTERN AND DESIGNATION	2012-03-28	AK
C	CHANGED HOLE PATTERN	2018-06-29	JA

ITEM NO.	DESCRIPTION	DRAWING NO.	QTY.
1	FLANGE	DRAW. No: 1111298	1
2	S-50	DRAW. No: 103326 TYPE 2	1
3	FIXING	DRAW. No: 1111297	4
4	SCREW	M6S M6x20	4
5	NUT	M6M M6	4

Ritad Drawn	Kontr. Check	Granskad Reviewed	Godkänd Approved	Tolerans där ej annat anges Tolerance unless otherwise not stated. ISO 13920 BF	Smst. nr. Assembly drawing no.	Ersätter Replaces	E
BO	JA	LS	ML	Ytjämnhet där ej annat anges Surface finish otherwise not stated.		Ersatt av Replaced of	Vikt Weight
110825	180629	180703	180704			Alla mått och uppgifter avser färdig produkt om ej annat anges All measures and other information refer to finished products unless otherwise not stated.	
						Kund ordernr. Customer order no	
						Ritn. nr. Draw. no.	Rev.
						1111296	C