

THIS DOCUMENT MUST NOT BE COPIED WITH-
OUT OUR WRITTEN PERMISSION, AND THE CON-
TENTS THEREOF MUST NOT BE IMPARTED TO A
THIRD PARTY NOR BE USED FOR ANY UNAUTHOR-
ISED PURPOSE. CONTRAVENTION WILL BE PROS-
ECUTED.

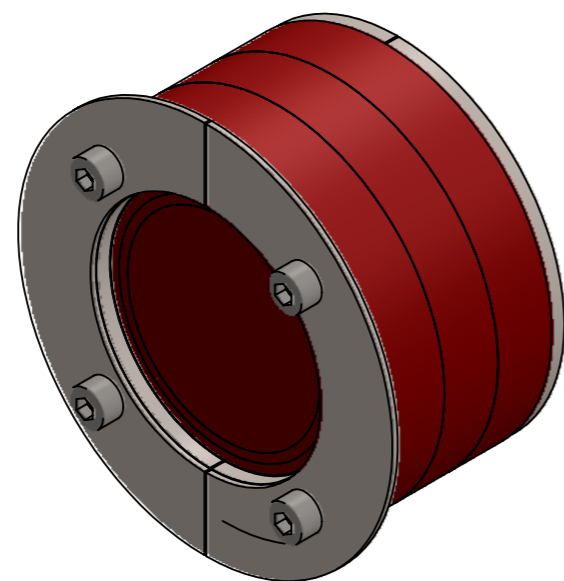

REVISIONS			
REV.	DESCRIPTION	DATE	SIGNATURE
A	FOR MANUFACTURING	2009-04-03	TF
B	ADDED FLANGE	2017-09-05	JA

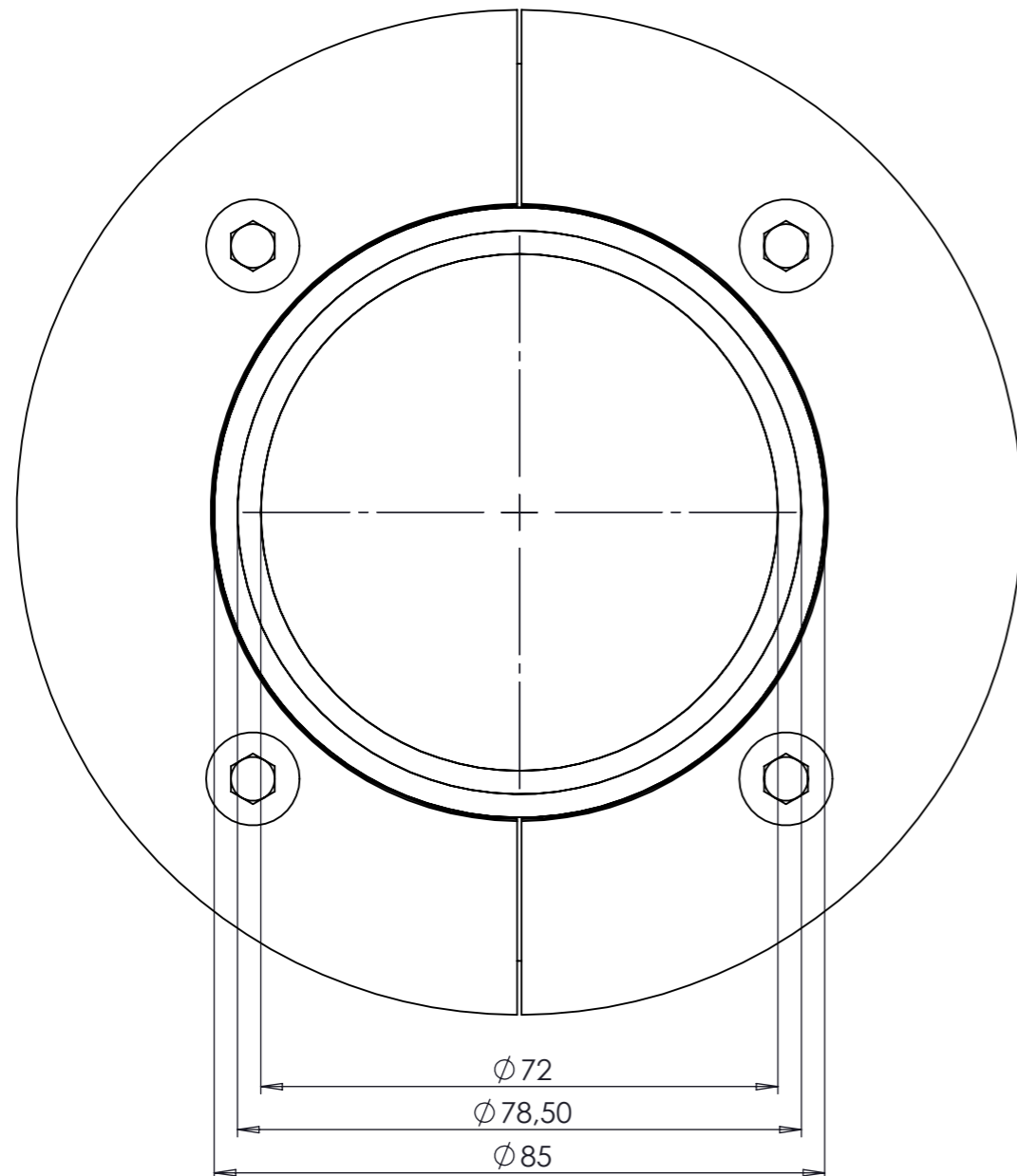
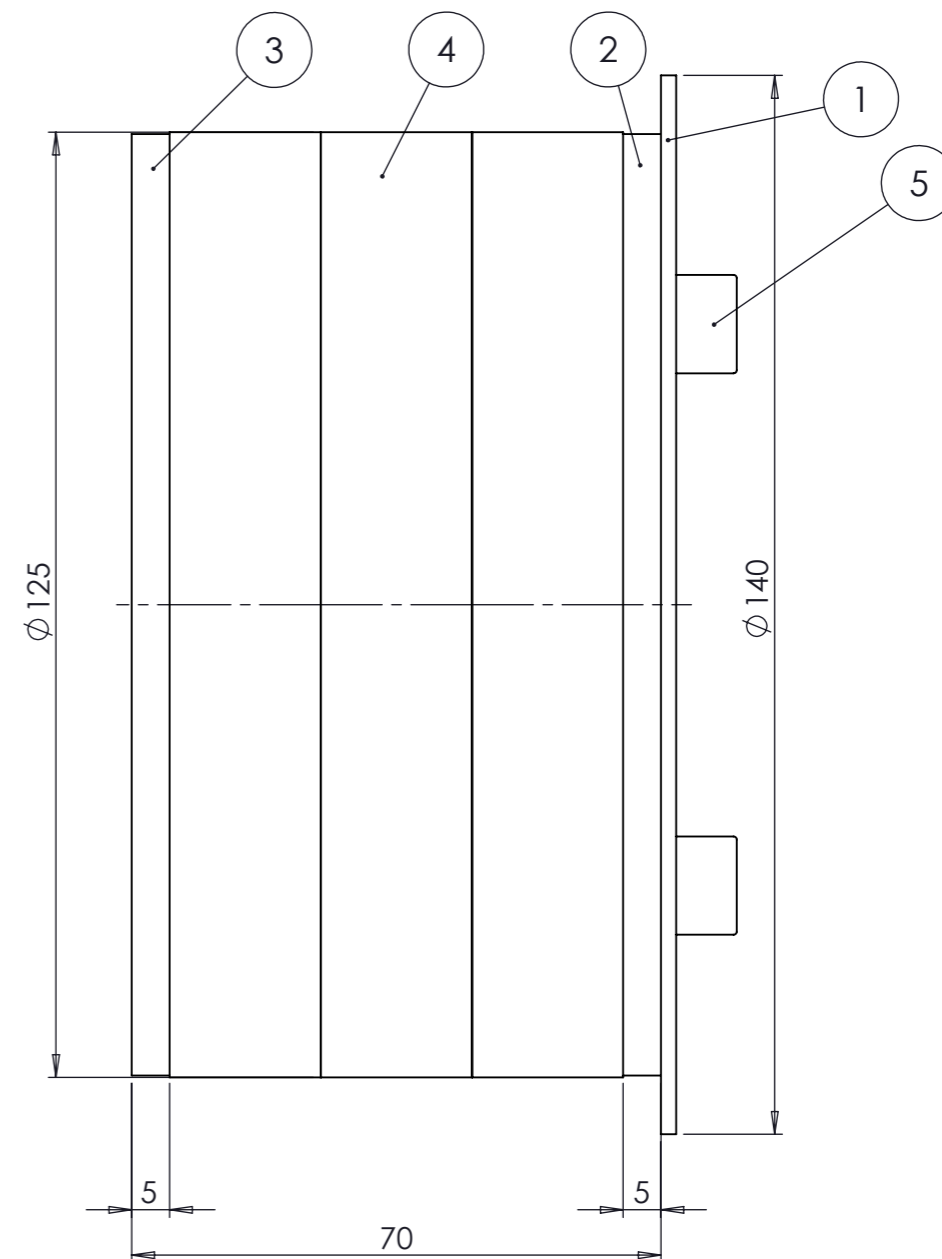

ITEM NO.	TITLE	DRAW. No. / DESCRIPTION / MATERIAL	QTY.
1	CAPTURE PLATE	361L 2mm	1
2	FRONT PLATE	1100865	1
3	BACK PLATE	1100865	1
4	RUBBER SEAL	1100866	3
5	SCREW	ISO 4762 - M8 x 70	4

Ritad Drawn	Kontr. Check	Granskad Reviewed	Godkänd Approved	Tolerans där ej annat anges Tolerance unless otherwise not stated.	Smst. nr. Assembly drawing no.	Ersätter Replaces	E
B0	JA	LS	ML	Ytjämnhet där ej annat anges Surface finish otherwise not stated.		Ersatt av Replaced of	Vikt Weight 2 Kg
090326	170906	180831	180831			Alla mått och uppgifter avser färdig produkt om ej annat anges All measures and other information refer to finished products unless otherwise not stated.	
				SR-125		Kund ordernr. Customer order no	
						Ritn. nr. Draw. no.	Rev.
						1090116	B