

THIS DOCUMENT MUST NOT BE COPIED WITHOUT
 OUR WRITTEN PERMISSION, AND THE CONTENTS
 THEREOF MUST NOT BE IMPARTED TO A THIRD
 PARTY NOR BE USED FOR ANY UNAUTHORIZED
 PURPOSE. CONTRAVENTION WILL BE PROSECUTED.

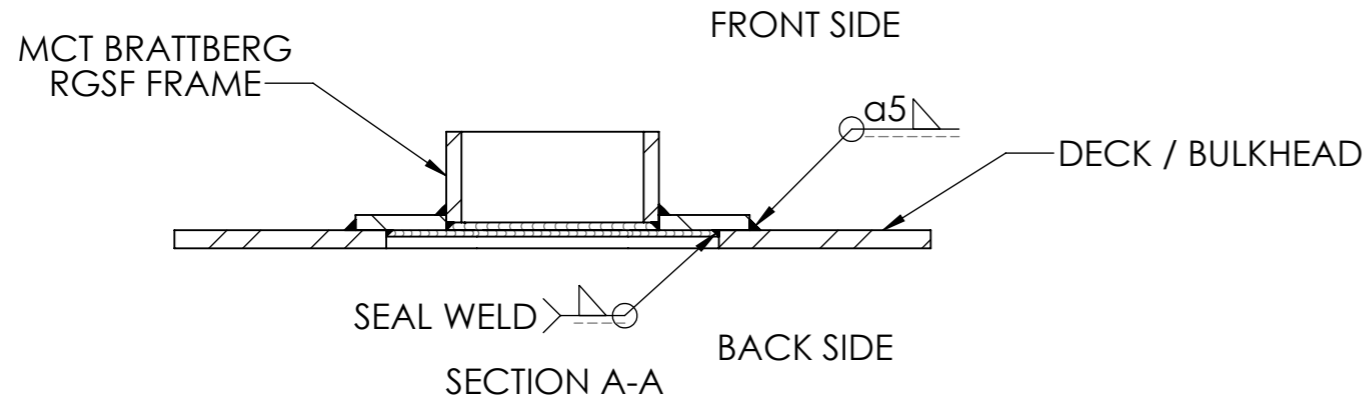

REVISIONS			
REV.	DESCRIPTION	DATE	SIGNATURE
A		2014-09-04	AK
B	ADDED WRITTEN INSTRUCTION	2015-10-26	AK

1. Position the RGSF frame flat to the bulkhead or deck.
2. Tack weld on the front side of the frame in each corner and then in every 200 mm between corners.
3. Continue welding around the front side of the frame in practical order.
4. Complete by seal welding around the rear side of the frame

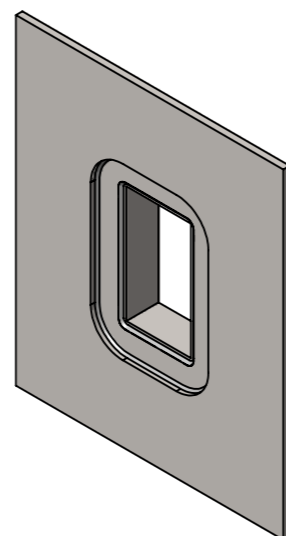
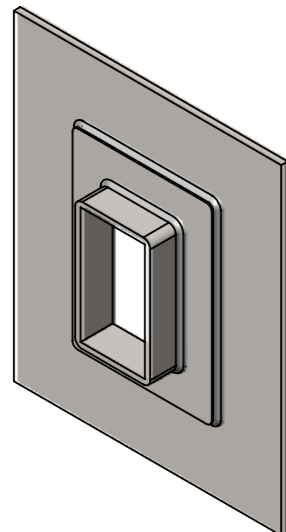
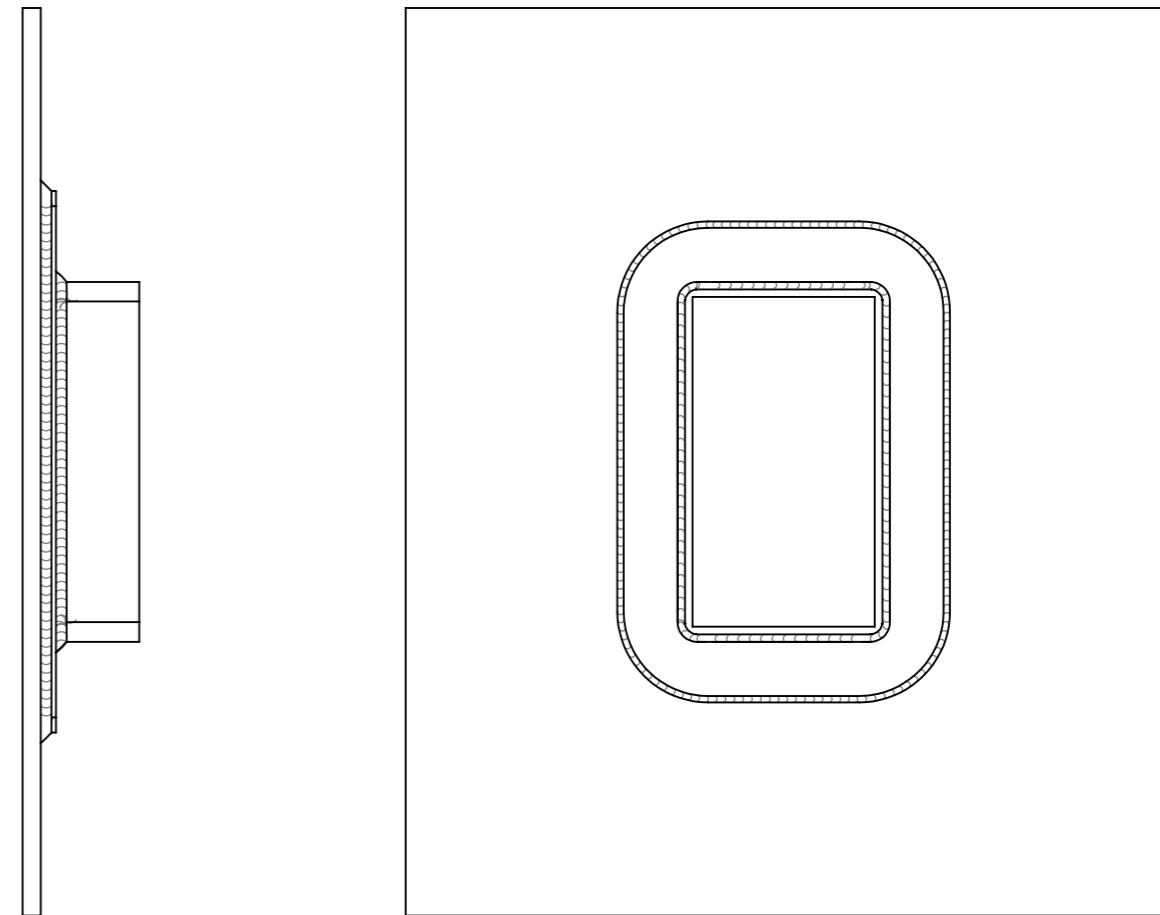
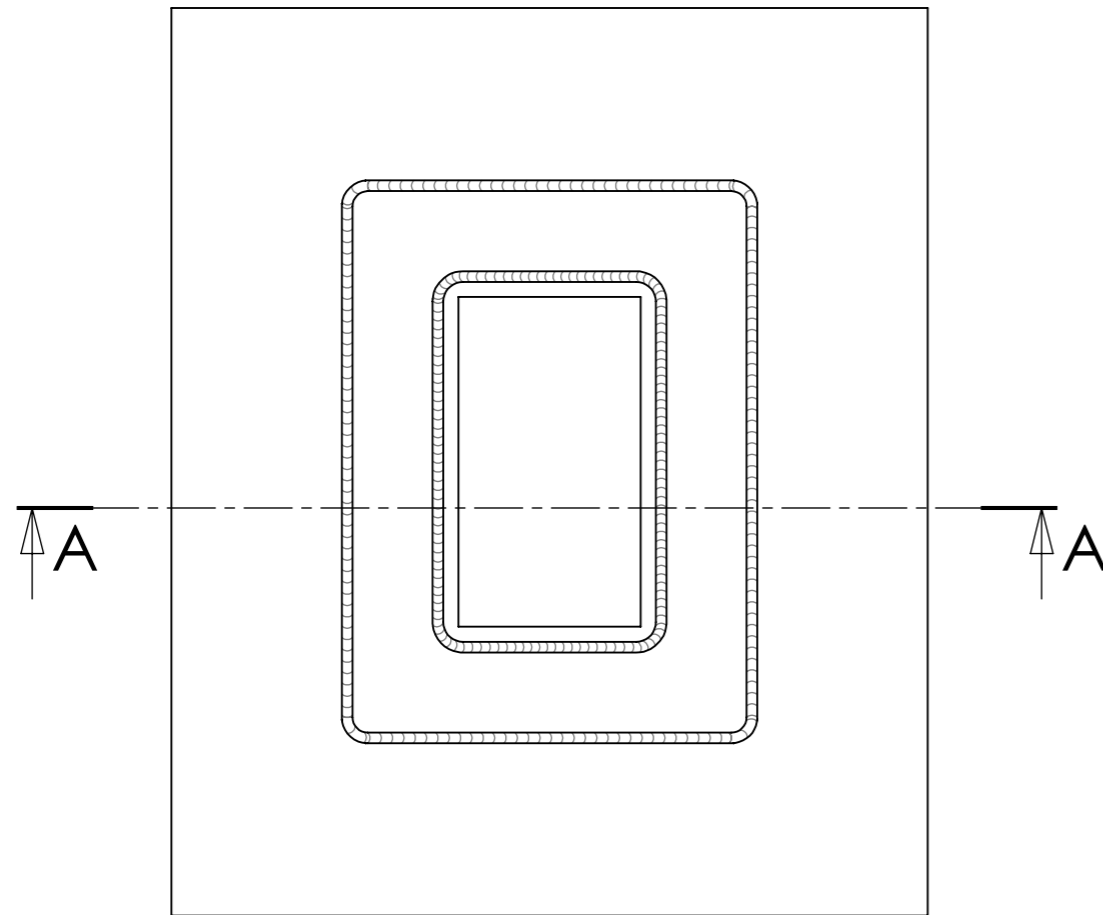

Ritad Drawn	Kontr. Check	Granskad Reviewed	Godkänd Approved	Tolerans där ej annat anges Tolerance unless otherwise not stated.	Smst. nr. Assembly drawing no.	Ersätter Replaces	E
AK	AK	JF	BJ	Ytjämnhet där ej annat anges. Surface finish otherwise not stated.	Material	Ersatt av Replaced of	Vikt Weight
140904	151026	151026	151026	Alla mått och uppgifter avser färdig produkt om ej annat anges All measures and other information refer to finished products unless otherwise not stated.		Kund ordernr. Customer order no	
				WELD INSTRUCTION RGSF FRAMES		Ritn. nr. Draw. no.	Rev.
						1140371	B